

# QUICK TANKS, Inc.

P.O.Box 338, Kendallville, IN 46755  
800-348-2514 Fax 800-348-1514

NON-CODE QC61® GALVANIZED VERTICAL TANKS  
QST SOFTNER EXCHANGE  
NSF/ANSI® STANDARD 61 CERTIFIED  
ALSO CERTIFIED TO NSF/ANSI STANDARDS 61-ANNEX G and 372  
125 PSIG WORKING PRESSURE

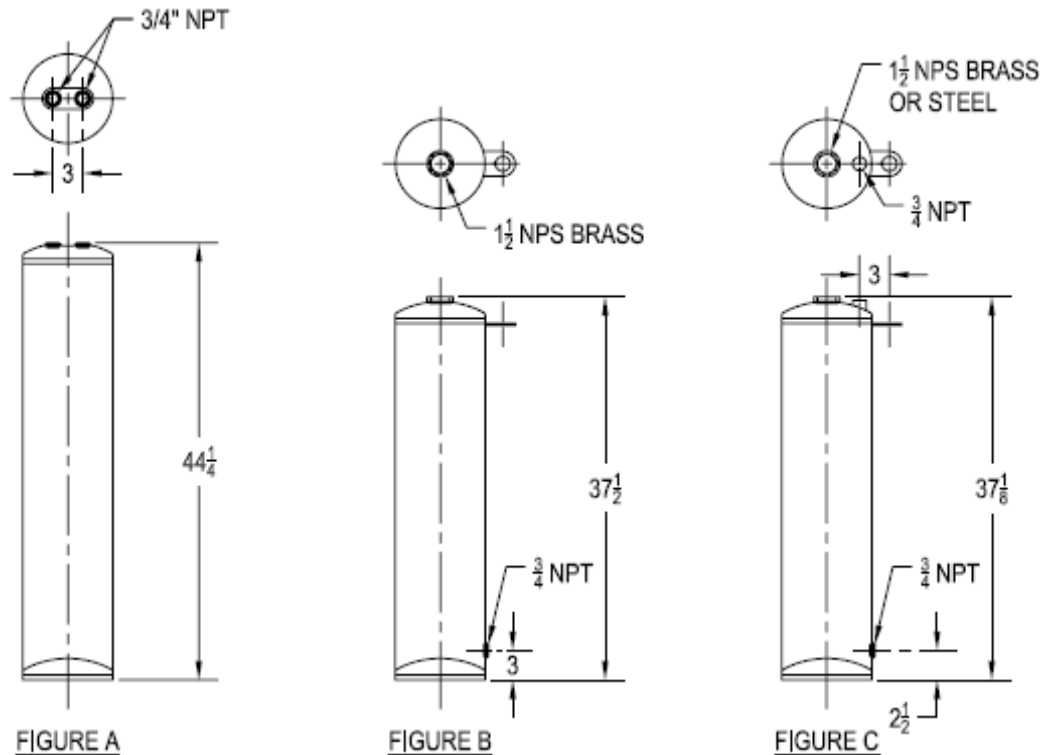

OPENINGS SHOWN IN EACH FIGURE ARE FOR THESE STANDARD TANKS, WORKING PRESSURES, TANK SIZES, AND REQUIRED FITTINGS MAY VARY WITH YOUR APPLICATION. CALL US WITH YOUR NEEDS AND WE WILL PROMPTLY PROVIDE YOU WITH COMPETITIVE QUOTATIONS FOR CUSTOMIZED TANKS.

MODEL	FIGURE	DIA. X SHELL	TOP FITTING	WEIGHT
QST736GB	B	7 X 36	BRASS	29
QST736GSC	C	7 X 36	STEEL	29
QST736GBC	C	7 X 36	BRASS	29
QST742G	A	7 X 42	STEEL	28
QST836GS	C	8 X 36	STEEL	30
QST836GB	C	8 X 36	BRASS	30
QST936GS	C	9 X 36	STEEL	40
QST936GB	C	9 X 36	BRASS	40
QST942G	A	9 X 42	STEEL	40